

MISCELLANEOUS EQUIPMENT: NRV - SCREEN

Since 1997 Pneumix has been active in bulk handling. During this period, we have developed special dedicated products to transport the catalyst and additive. It is very important, in case purge air pressure fails, to prevent back flow of catalyst from the regenerator. For this purpose, we have designed a full-bore Non return Valve. All normal NRV valves used are designed for gases and these valves tend to be blocked very often. With the Pneumix NRV set, you have a reliable and very easy to service valve. Standard size.



Art.no PNO-0035



In order to prevent large particles, lumps or steel parts to enter the shot pot and cause problems in the automatic loading unit we designed a flanged type screen. This screen can be installed in the filling line from the hopper to the loader. Advantage of the screen is that it is very easy to clean and over dimensioned. Connection 3" Ansi flange.

Art.no GLO - 1000

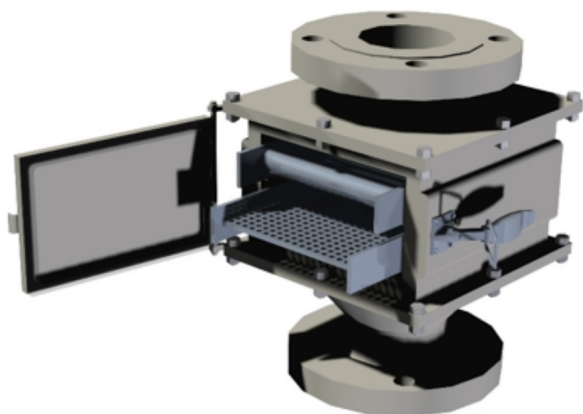

PREFERRED SUPPLIER FOR

Axens
IFP Group Technologies

Uop
A Honeywell Company